

**Bishamon**  
**Blue Label**  
from Japan



**HAND  
PALLET  
TRUCK**

**Bishamon**<sup>®</sup>

**High Standards and experienced Engineering provide superior Quality!**

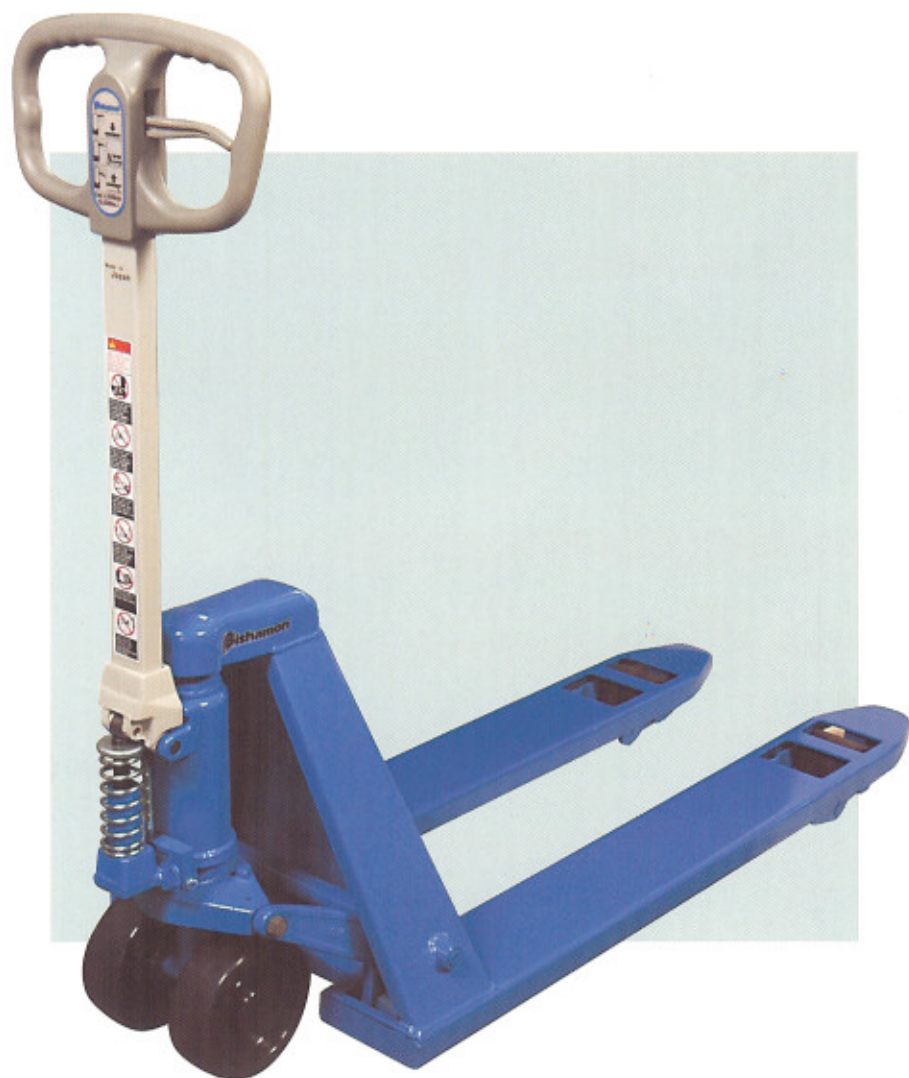

### New Valuable Features

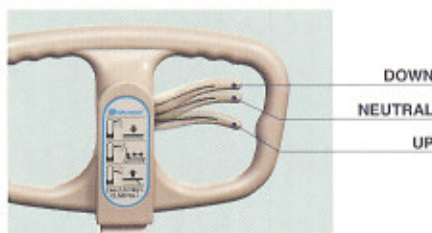

- **Comfortable Molded Grip Handle**  
New molded handle design provides comfort and a strong grip
- **3 Position Fingertip Control**  
3 position Control Lever provides easy fingertip control of complete hydraulic system

### Standard Features



- **Polyurethane Wheels**  
Rugged Polyurethane Wheels are standard
- **Lead Free Paint**  
Bishamon pallet trucks are painted with environmentally friendly lead free paint.

### Optional Features



- **Bogie Wheels**  
Bogie Wheels are standard with Model BM30



- **Parking Brake**

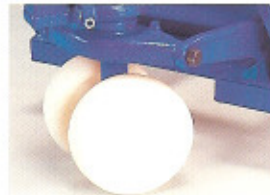

- **Wheels**  
Nylon Wheels - available with Model BM20 & 25 (Except Low Profile Model)  
Aluminum hub steer wheels and steel hub fork (load) wheels are available as an option.



# Specifications of Standard and Special Width Models

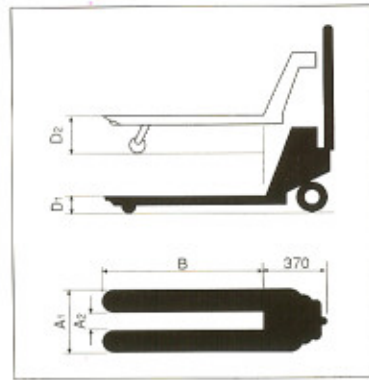

<b>A</b>	Standard Model	2,000 Kgs. Capacity	Fork M/M Height	80 mm
<b>B</b>	Special Width Model	2,000 Kgs. Capacity	Fork M/M Height	80 mm
<b>C</b>	Standard Model	2,500 Kgs. Capacity	Fork M/M Height	80 mm
<b>D</b>	Standard Low Profile Model	1,500 & 2,500 Kgs. Capacity	Fork M/M Height	65 mm
<b>E</b>	3 Ton Capacity Model	3,000 Kgs. Capacity	Fork M/M Height	83 mm
<b>F</b>	50 mm Low Profile Model	1,200 Kgs. Capacity	Fork M/M Height	50 mm

Model	Model No.	Capacity (Kgs.)	Fork Dimension						Wheel Material	Weight (Kgs.)								
			A <sub>1</sub>		A <sub>2</sub>		B				D <sub>1</sub>		D <sub>2</sub>					
			mm	inch	mm	inch	mm	inch			mm	inch	mm	inch				
<b>A</b>	BM20SS	2,000	520	(20 1/2")	214	(8 1/2")	810	(32")	80	(3 1/8")	200	(7 7/8")	V/V(N/N)	72				
	BM20S						980	(42")						75				
	BM20M						1,070	(48")						79				
	BM20L						1,150	(45 1/4")						81				
	BM20C						1,070	(42")						85				
	BM20LL						1,220	(48")						88				
<b>B</b>	BM20-46SS	2,000	460	(18 1/8")	154	(6")	810	(32")	80	(3 1/8")	200	(7 7/8")	V/V(N/N)	70				
	BM20-46S						980	(38 1/2")						74				
	BM20-60M						1,070	(42")						82				
	BM20-60L						1,150	(45 1/4")						85				
<b>C</b>	BM25SS	2,500	520	(20 1/2")	214	(8 1/2")	810	(32")	80	(3 1/8")	200	(7 7/8")	V/V(N/N)	83				
	BM25S						980	(38 1/2")						86				
	BM25M						1,070	(42")						89				
	BM25L						1,150	(45 1/4")						92				
	BM25C						1,070	(42")						95				
	BM25F						1,150	(45 1/4")						98				
	BM25LL						1,220	(48")						99				
<b>D</b>	BM15SS-L	1,500	520	(20 1/2")	214	(8 1/2")	810	(32")	65	(2 1/2")	165	(6 1/2")	V/V(N/V)	68				
	BM15M-L						1,070	(42")						75				
	BM15LL-L	1,220					(48")	83										
	BM25M-L	2,500					520	(20 1/2")						214	(8 1/2")	1,070	(42")	85
	BM25LL-L						685	(27")						379	(15")	1,220	(48")	95
<b>E</b>	BM30M	3,000	520	(20 1/2")	214	(8 1/2")	1,070	(42")	83	(3 1/4")	203	(8")	V/V(Bogie Wheels)	105				
	BM30LL		685	(27")	379	(15")	1,220	(48")						110				
<b>F</b>	BM15SS-L50	1,200	520	(20 1/2")	214	(8 1/2")	810	(32")	50	(2")	140	(5 1/2")	V/V	68				
	BM15M-L50						1,070	(42")						75				
	BM15LL-L50						1,220	(48")						83				

\* Wheel Material.....(Steering Wheel/Fork Wheel)  
Specifications are subject to change without notice.

V = Polyurethane, N = Nylon

ECBM'06.11-5000PR